

# OVERGROUND TANK D2000

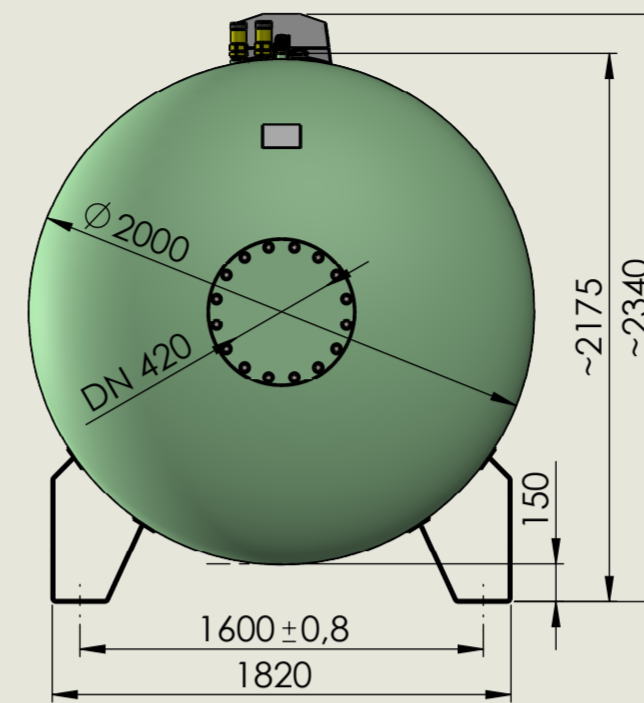
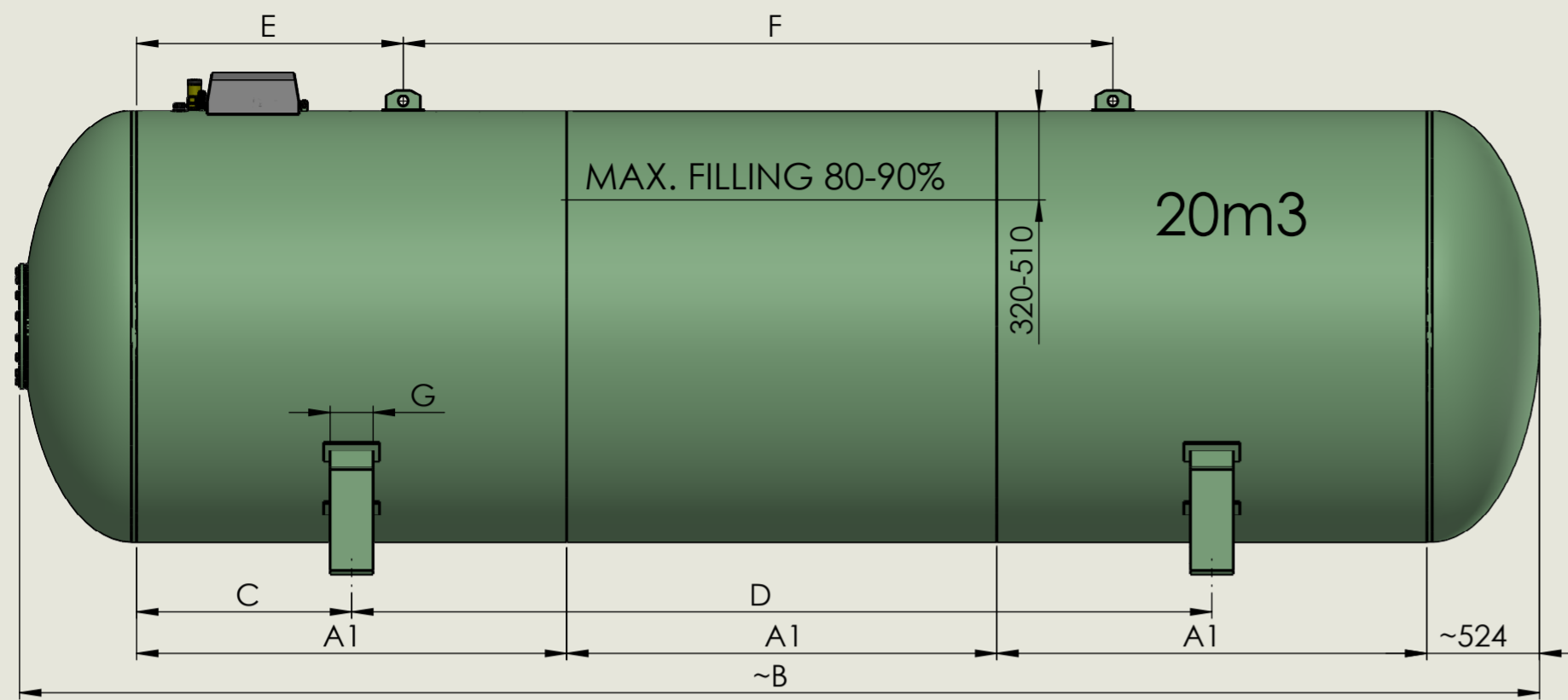

VOLUME (m3)	A1 (mm)	QUANTITY A (ks)	B (mm)	C (mm)	D (mm)	E (mm)	F (mm)	G (mm)	WEIGHT (kg)
8,4	2000	1	~3085	300	1400	1000	-	200	1610
10,0	2500	1	~3585	300	1900	1130	-	200	1810
14,5	2000	2	~5080	750	2500	1135	1500	200	2410
17,7	2500	2	~6080	500	4000	1135	2500	200	2810
20,0	2000	3	~7070	1000	4000	1240	3300	200	3210
25,5	2500	3	~8570	750	2x3000	1885	4000	200	3850
26,7	2000	4	~9060	550	2x3200	1385	5000	200	4050
33,2	2000	5	~11050	1000	2x4000	2385	5000	200	4850
33,2	2500	4	~11050	800	2x4000	2885	4000	200	4850
39,0	2000	6	~13040	550	2x5200	3385	5000	200	5650
40,0	2500	5	~13550	1250	2x5000	3635	5000	200	5850

MAX. WORKING PRESSURE	TESTING PRESSURE	MAX. WORKING TEMPERATURES
15,6 BAR	22,3 BAR	-20/+40 °C (-40/+40 °C)
16,7 BAR	23,9 BAR	-20/+45 °C (-40/+45 °C)
17,6 BAR	25,2 BAR	-20/+50 °C (-40/+50 °C)

NAME	MANUFACTURER	TYPE	QUANTITY	MATERIAL
FILLER VALVE	REGO	7501	1	2.0402
FILLER VALVE	REGO	7579	1	2.0402
FILLER VALVE	REGO	7879	1	2.0402
FILLER VALVE	GOK	FV/54020	1	2.0402
FILLER VALVE	GOK	FV/54010	1	2.0402
FILLER VALVE	SRG	481	1	2.0402
FILLER VALVE	OMECA	VRN 88	1	2.0402
FILLER VALVE	OMECA	VRN 20	1	2.0402
GAS SERVICE VALVE	REGO	9101 DK	1	2.0402
GAS SERVICE VALVE	REGO	7556 R	1	2.0402
GAS SERVICE VALVE	GOK	55212	1	2.0402
GAS SERVICE VALVE	GOK	FST3.1VK/55 220 71	1	2.0402
GAS SERVICE VALVE	SRG	483-433-1001	1	2.0402
GAS SERVICE VALVE	SRG	489-914	1	2.0402
GAS SERVICE VALVE	OMECA	8075	1	2.0402
GAS SERVICE VALVE	OMECA	GSE 35	1	2.0402
GAS SERVICE VALVE	OMECA	GS 41	1	2.0402
GAS SERVICE VALVE	OMECA	GS 80	1	2.0402
LIQUID SERVICE VALVE	REGO	7550PX	1	2.0402
LIQUID SERVICE VALVE	REGO	7590 UT	1	2.0402
LIQUID SERVICE VALVE	REGO	7591 UT	1	2.0402
LIQUID SERVICE VALVE	GOK	FEV/55 160 00	1	2.0402
LIQUID SERVICE VALVE	SRG	484-011-1001	1	2.0402
LIQUID SERVICE VALVE	OMECA	RL 15	1	2.0402
LIQUID SERVICE VALVE	OMECA	VL 13	1	2.0402
LEVEL GAUGE	ROCHESTER	6281	1	-
LEVEL GAUGE	SRG	487-917	1	-
LEVEL GAUGE	SRG	487-917	1	-
SAFETY VALVE EXTERNAL	REGO	3131+CD31	2	2.0402
SAFETY VALVE EXTERNAL	GOK	ATVS 20	2	2.0402
SAFETY VALVE EXTERNAL	SRG	485-911	2	2.0402
SAFETY VALVE EXTERNAL	OMECA	EU20/ST20	2	2.0402
SAFETY VALVE EXTERNAL	REGO	3132+CD32	1	2.0402
SAFETY VALVE EXTERNAL	GOK	ATVS 25	1	2.0402
SAFETY VALVE EXTERNAL	SRG	485-415	1	2.0402
SAFETY VALVE EXTERNAL	OMECA	EU25/ST25	1	2.0402
SAFETY VALVE EXTERNAL	REGO	3135+CD35	1	2.0402
SAFETY VALVE EXTERNAL	GOK	ATVS 32	1	2.0402
SAFETY VALVE EXTERNAL	SRG	485-417	1	2.0402
SAFETY VALVE EXTERNAL	OMECA	EU30/ST32	1	2.0402
SAFETY VALVE INTERNAL	SRG	486-924-1056	1	2.0402
SAFETY VALVE INTERNAL	GOK	SV-A8684/56 112 42	1	2.0402
SAFETY VALVE INTERNAL	OMECA	66.1129	1	2.0402
SAFETY VALVE INTERNAL	REGO	8684G	1	2.0402
SAFETY VALVE INTERNAL	REGO	8685G	1	2.0402

## STANDARD VALVES SET

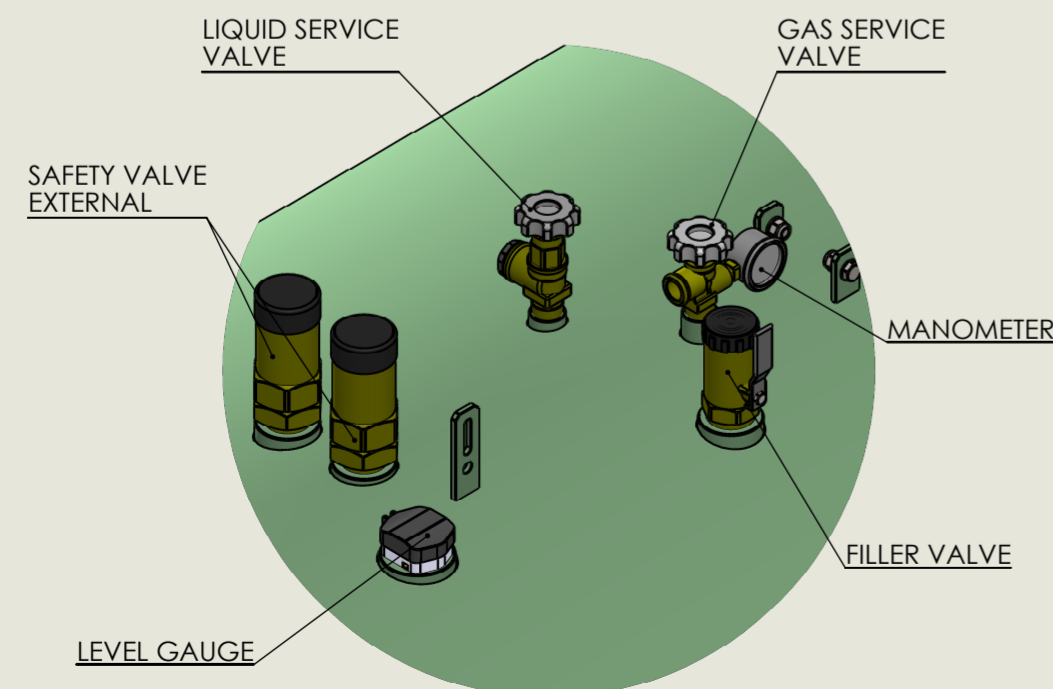

## STANDARD DESIGN ACCORDING TO EN ISO 12542\_A1, AD2000, PED 2014/68/EU

MAXIMUM WORKING PRESSURE: 15,6 bar  
 TESTING PRESSURE: 22,3 bar  
 WORKING TEMPERATURES: -20/+40°C  
 MAXIMUM FILLING: 85 %  
 CORROSION ALLOWANCE: 0 mm  
 WELD FACTOR MAXIMUM WORKING PRESSURE: 1

WELDED JOINTS EVALUATION ACCORDING TO AD-HP0

**ADDITIONAL WELDING MATERIALS:**  
 WELDS 135 - WIRE 1,2 mm EN ISO 14341\_A  
 WELDS 121 - WIRE 3,0 mm EN ISO 14171\_A  
 WELDS 141 - WIRE 2,0 mm EN ISO 636\_A

**SURFACE FINISH:**  
 SAND BLASTED Sa 2,5  
 POLYURETHANE COATING MIN. 120µm  
 RAL 9010 (RAL 6019, RAL 258 010)